

DATE : _____
TYPE : _____
PROJECT : _____
APPROVE BY : _____
SALE : THANASETH 0819289942



PRODUCT IMAGE



PRODUCT NAME : MULTIPLE RECESSED DOWNLIGHT
BRAND : LIGHTTRIO
ITEM CODE : DH-521
MATERIAL : STEEL SHEET
COLOR : WHITE TRIM
LAMP TYPE : LED 220V
HOLDER : GX5.3
WATT : 7.5W 220V
LUMEN : 660lm.
KELVIN : 4,000K
CEILING HIGH : 3m.
DIMMABLE : YES
WARRANTY : 2 YEARS
IP : 20

DIMENSION

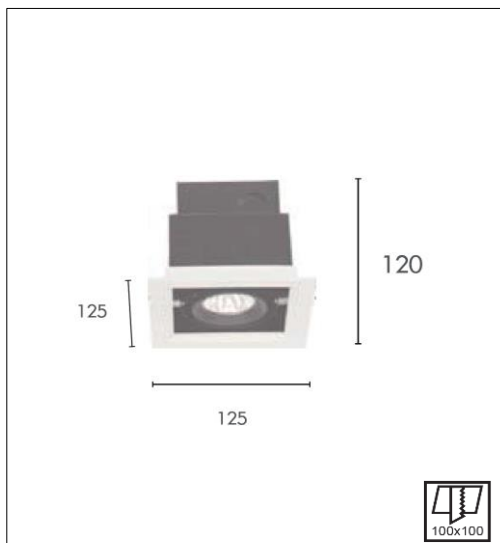

REMARK :

Application



Home



Retail



Office



Hotel