

DATE : _____
 TYPE : _____
 PROJECT : _____
 APPROVE BY: _____
 SALE : THANASETH 0819289942



PRODUCT IMAGE



PRODUCT NAME : MULTIPLE RECESSED DOWNLIGHT
 BRAND : LIGHTTRIO
 ITEM CODE : LEO-20010-2
 MATERIAL : STEEL SHEET
 COLOR : WHITE TRIM
 LAMP TYPE : LED
 HOLDER : GU5.3
 WATT : 2x7W
 LUMEN : 2x470lm.
 KELVIN : 4,000K
 CEILING HIGH : 3m.
 DIMMABLE : NO
 WARRANTY : 2 YEARS
 IP : 20

DIMENSION

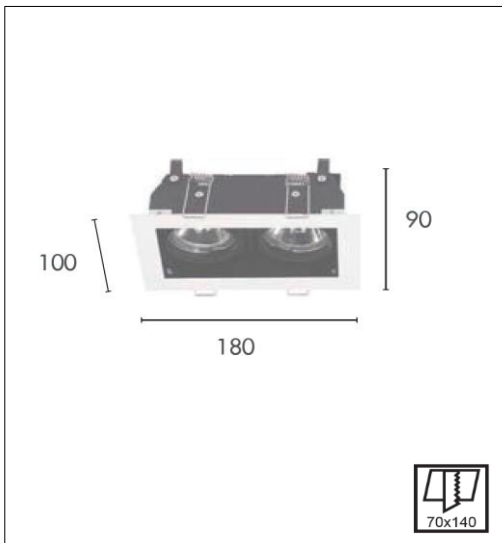

Application

